

## SECTION IX

### MODULAR PLASTIC SCREW SECTION IX

Introduction.....	166
Warning and Safety Reminder .....	167
Technical and Design Data.....	168

Another *Martin* patented Innovation. We'll give your customers another reason to give you their business.

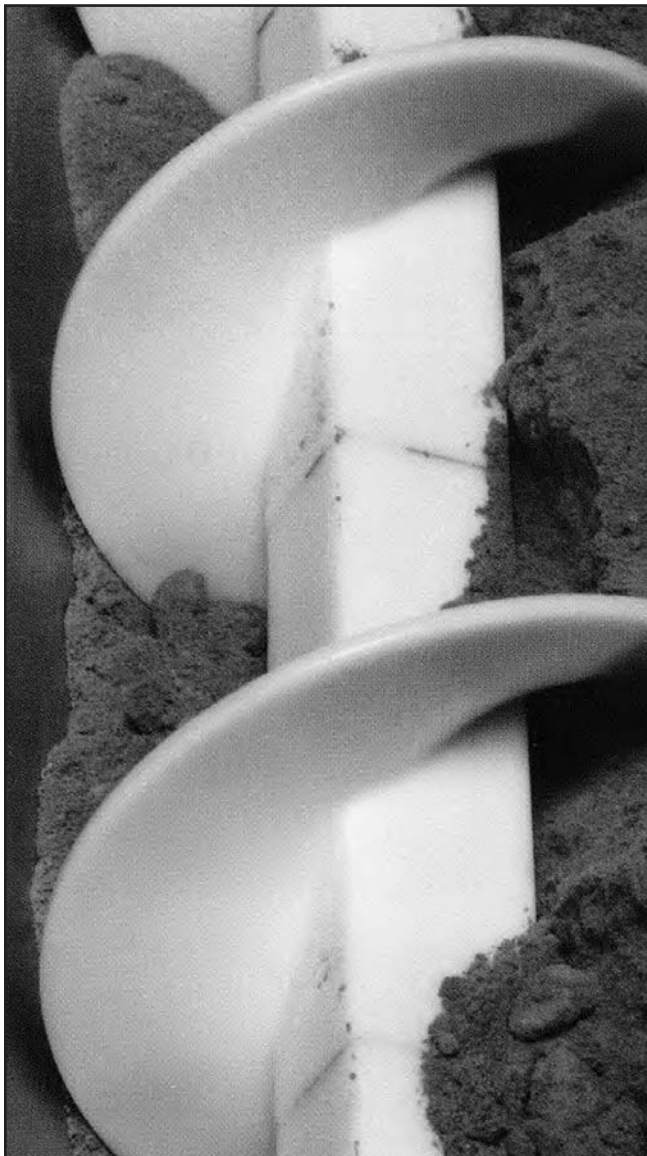

- Plastic modules consist of a helical flight spiraling once around a hollow square hub.
- Eliminates need to spot or continuously weld metal flights to shaft.
- Polyurethane - used where impact/abrasive wear is a problem. Lab tests show it up to 3 times more wear resistant than carbon or stainless steel in certain applications.
- All-plastic material does not corrode, is impervious to acids, caustics and other chemicals.
- Durable, lightweight injection-molded modules stack on square tube.
- Polypropylene - general purpose material for high temperature service.
- FDA approved for food contact.
- Highly resistant to corrosion.
- Modules are individually replaceable without welding or burning.
- Assembled conveyor is comparatively lightweight, easier to handle, and bearing life is prolonged.
- Polyethylene - general purpose material. FDA approved for food contact.
- Good abrasive and excellent corrosion resistance in a wide temperature range.
- Slick surface simplifies cleaning.

\*Conveyors shown without cover for illustration purposes only. Please follow manufacturing safety guidelines when operating conveyors.

## WARNING & SAFETY REMINDER

Safety must be considered a basic factor in machinery operation at all time. *Most accidents are the results of carelessness or negligence.* All rotating power transmission products are potentially dangerous and must be guarded by the contractor, installer, purchaser, owner, and user as required by applicable laws, regulations, standards, and good safety practice. Additionally specific information must be obtained from other sources including the latest editions of American Society of Mechanical Engineers; (ANSI) Safety Code. A

copy of this standard may be obtained from the American Society of Mechanical Engineers at 345 East 47th Street, New York, NY 10017 (212-705-7722).

It is the responsibility of the contractor, installer, purchaser, owner, and user to install, maintain, and operate the parts or components manufactured and supplied by Thomas Conveyor, in such a manner as to comply with the Williams-Steiger Occupational Safety Act and with all state and local laws, ordinances, regulations, and the American National Standard Institute Safety Code.

## CAUTION

***Guards, access doors, and covers must be securely fastened before operating any equipment.***

If parts are to be inspected, cleaned, observed, or general maintenance performed, **the motor driving the part or components is to be locked out electrically in such a manner that it cannot be started by anyone**, however remote from the area. Failure to follow these instructions may result in personal injury or property damage.

## WARNING

***Warning: Static Electricity***

Static Electricity may accumulate on modular plastic conveyor screws which carry non-conductive materials and may produce an electrical spark. **Do Not Use to Convey Non-Conductive Materials in a Combustible Environment.**

# Modular Plastic Screw Conveyors - Design Data



## Solutions to Screw Conveyor Problems

- Currently available in 6", 9" and 12" diameters, in right hand only.
- Assembled conveyors compatible with CEMA standards; easily retro-fitted.
- Flight modules available in polyethylene, polypropylene, and polyurethane, each with characteristics to fill specific needs (see Technical Data).
- Flights and hubs are integrally molded, resulting in consistent diameter, pitch and thickness with a uniform, smooth finish.
- Plastic modules eliminate metal contamination to food.
- Assembled conveyor is light in weight, is safe and easy to handle; bearing life is prolonged.
- Plastic flights may operate at close clearances, or when conveying many materials, directly on the trough without danger of metal contamination.
- Modules are individually replaceable.
- Balance is excellent allowing high speed operation.

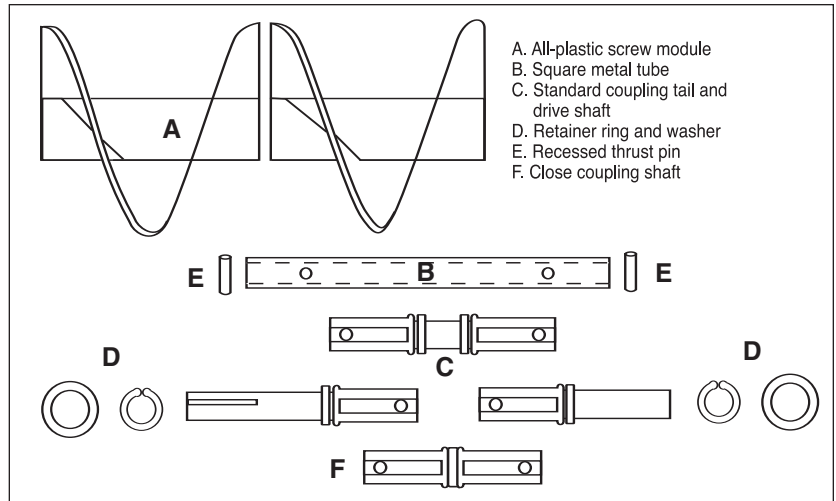

The *Martin* Screw Conveyor System consists of plastic modules stacked on a square metal tube. A shaft is inserted at each tube end and secured by a recessed pin. Modules are secured at tube ends by retainer rings and washers.

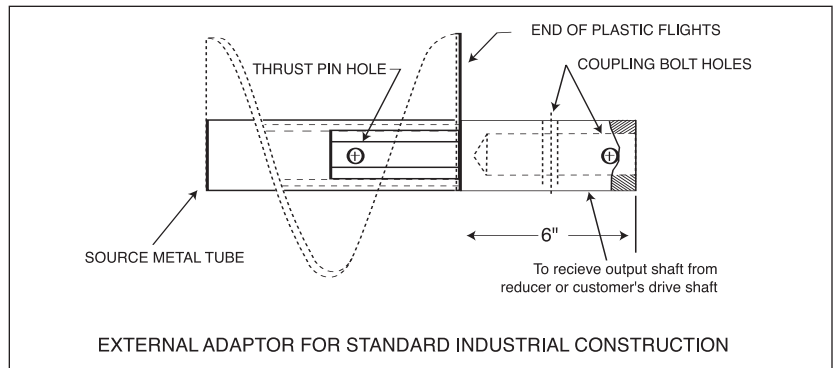

**MOUNTED SCREW CONVEYOR**

**END CONSTRUCTION**

DIAMETER	AVAILABLE SHAFTS		WEIGHT PER FOOT	
	FULL PITCH	SHORT PITCH	FULL PITCH	SHORT PITCH
6"	1-1/2", 2"		4.1 lb	4.3 lb
9"	1-1/2", 2"		4.5 lb	5.2 lb
12"	2", 2-7/16"		8.0 lb	9.5 lb
14"	NOT CURRENTLY AVAILABLE			
16"	NOT CURRENTLY AVAILABLE			

Weights shown as for polyethylene or polypropylene on stainless steel tube, polyurethane approximately 10% heavier.

DIAMETER	FULL PITCH	SHORT PITCH	FLIGHT THICKNESS	OUTSIDE HUB	INSIDE HUB
6"	9.05"	4.53"	.25"	2.51"	2.03"
9"	9.05"	4.53"	.25"	2.51"	2.03"
12"	11.72"	5.86"	.34"	3.17"	2.53"
14"	NOT CURRENTLY AVAILABLE				
16"	NOT CURRENTLY AVAILABLE				

**FLIGHT THICKNESS MODULES**

## Screw Conveyor Capacities

CUBIC FEET PER HOUR PER R.P.M. FULL PITCH HORIZONTAL				
DIAMETER	PITCH	CONVEYOR LOAD		
		FULL	45%	30%
6"	9"	5.72	2.75	1.72
9"	9"	16.73	7.53	5.02
12"	12"	39.27	17.67	11.78
14"	14"	NOT CURRENTLY AVAILABLE		
16"	16"	NOT CURRENTLY AVAILABLE		

## Maximum Recommended Conveyor Speed / Horizontal Operation / R.P.M.

DIA.	SHAFT	TYPE OF INTERMEDIATE BEARING	
		WOOD, NYLATRON, BRONZE	CLOSE COUPLED*
6"	1-1/2"	165	90
9"	1-1/2"	165	80
9"	2"	150	80
12"	2"	145	70
12"	2-7/16"	140	70
14"	2-7/16"	NOT CURRENTLY AVAILABLE	
14"	3"	NOT CURRENTLY AVAILABLE	
16"	3"	NOT CURRENTLY AVAILABLE	

\* Close coupled limitations apply to screw lengths over 12 ft. (for 6" and 9" dia.) or 15 ft. (for 12" dia). For longer lengths or units without intermediate bearing supports, locate end bearing no more than 3-1/8" (for 6" size); 4-5/8" (for 9" size); or 6-1/8" (for 12" size); centers above the inside bottom of the conveyor trough.

## Horsepower Ratings

DIA.	SHAFT	RATINGS FOR CARBON STEEL SHAFT & TUBE			
		50 R.P.M.	75 R.P.M.	100 R.P.M.	150 R.P.M.
6"-9"	1-1/2"	3.4	5.1	6.8	10.1
6"-9"	2"	5.6	8.4	11.2	16.8
12"	2"	8.0	12.0	16.0	24.0
12"	2-7/16"	9.1	13.6	18.2	27.3
14"	2-7/16"	NOT CURRENTLY AVAILABLE			
14"	3"	NOT CURRENTLY AVAILABLE			
16"	3"	NOT CURRENTLY AVAILABLE			

NOTE: The above limitations are based on *Marlin* modular plastic construction throughout. The use of coupling bolts, as required for an external adaptor, may reduce horsepower capacity.

## Materials of Construction

	POLYETHYLENE	POLYPROPYLENE	POLYURETHANE
FDA Approved	Yes	Yes	No
Abrasive Resistance	Good	Fair	Excellent
Corrosive Resistance	Excellent	Excellent	Good
Impact Resistance	Good	Fair	Excellent
Temperature Limit	-60° to +150° F	-40° to +220° F	-20° to +150°
Release	Excellent	Good	Good

Note: Release pertains to the capability of conveying "sticky" products.

## Design Data for Bonded Construction

Bonded Construction is used in the handling of a finished food product or for the conveying of any product in which it is necessary to guard against material entering the internal clearances between the modules or into the inside of the square tube.

The hubs of the individual modules are heat fused together, the ends of the flights may be fused or may be cut to create a "clean out"

gap, usually 1/8" to 1/4" wide. The ends are capped and fitted with an "O" ring to seal around the shaft. The cap may be of alternate construction as detailed below.

Bonded Construction has USDA acceptance for use as a component part of food processing equipment in federally inspected meat and poultry processing plants.

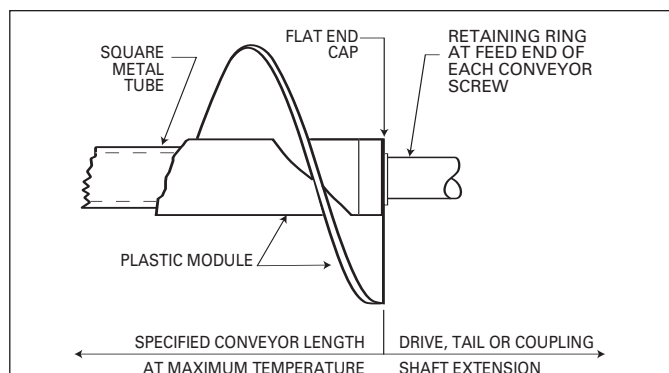

### FLAT END CAPS

Flat End Caps are the basic construction for conveying finished food products. Drive and Tail End Shafts are shipped factory installed. If used with coupling shafts, the thrust bearing must be at the feed end of the conveyor assembly. Retaining ring may be eliminated in some applications depending upon length and temperature involved.

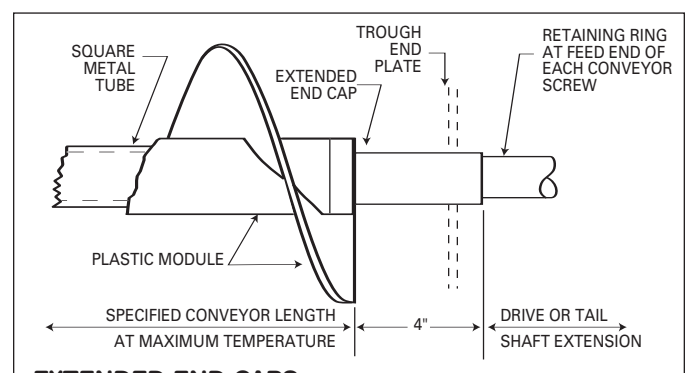

### EXTENDED END CAPS

Extended End Caps are used in the handling of products which require a total elimination of cracks and crevices on the conveyor screw. This precludes the use of coupling shafts and therefore limits the unit to one conveyor length, a maximum of 20 feet. Retainer rings and shafts are entirely outside the product area. Drive and Tail End Shafts are shipped factory installed.